

Doc. Number:

- Tentative Specification
- Preliminary Specification
- Approval Specification

MODEL NO.: DJ080IA
SUFFIX: 11A

Customer:	
APPROVED BY	SIGNATURE
Name / Title _____	
Note : Only for reference	

Please return 1 copy for your confirmation with your signature and comments.	

Approved By	Checked By	Prepared By
		楊哲彥

REVISION HISTORY

Version	Date	Page	Description
0.0	Jun,1,2015	All	Spec Ver.0.0 was first issued

Contents

1. General Specifications	1
2. Pin Assignment.....	2
3. Operation Specifications	5
3.1. Absolute Maximum Ratings	5
3.1.1. Typical Operation Conditions.....	5
3.1.2. Current Consumption.....	6
3.1.3. Backlight Driving Conditions.....	6
3.2. Power Sequence.....	7
3.3. Timing Characteristics	8
3.3.1. AC Electrical Characteristics.....	8
3.3.2. Input Clock and Data Timing Diagram	8
3.3.3. DC Electrical Characteristics.....	10
3.3.4. Timing.....	11
3.3.5. Data Input Format.....	11
3.3.6. Rest Timeing	113
4. Optical Specifications	14
5. Reliability Test Items	18
6. General Precautions.....	20
6.1. Safety	20
6.2. Handling	20
6.3. Static Electricity.....	20
6.4. Storage	20
6.5. Cleaning.....	20
7. Mechanical Drawing	21
8. Package Drawing.....	22
8.1 Packaging Material Table	22
8.2 Packaging Quantity.....	22
8.3. Packaging Drawing.....	23
8.4. Shipping Drawing.....	23

1. General Specifications

No.	Item	Specification	Remark
1	LCD size	8 inch (Diagonal)	
2	Driver element	a-Si TFT active matrix	
3	Resolution	1280 × 3(RGB) × 720	
4	Display mode	Normally Black, Transmissive	
5	Dot pitch	0.138(W) × 0.138(H) mm	
6	Active area	176.64(W) × 99.36(H) mm	
7	Module size	192.8(W) × 116.9(H) × 6.4(D) mm	Note 1
8	Surface treatment	Anti-Glare	
9	Color arrangement	RGB-stripe	
10	Interface	LVDS	
11	Backlight power consumption	TBD (Max.)	
12	Panel power consumption	TBD (Typ.)	
13	Weight	205 g (Max.)	

Note 1: Refer to Mechanical Drawing.

2. Pin Assignment

PCBa Connector is used for the module electronics interface. The recommended model is 20647-040E-01 manufactured by I-PEX.

Pin No.	Symbol	I/O	Function
1	NC	-	Keep floating
2	VDD	Power	External main and I/O power supply ; Power3V3
3	VDD	Power	External main and I/O power supply : Power3V3
4	NC	-	Keep floating
5	Reset	Input	Global reset pin, active low.
6	STBYB	Input	Standby mode setting pin, active low.
7	GND	Power	Ground
8	RXIN0-	Input	LVDS odd data 0-
9	RXIN0+	Input	LVDS odd data 0+
10	GND	Power	Ground
11	RXIN01-	Input	LVDS odd data 1-
12	RXIN01+	Input	LVDS odd data 1+
13	GND	Power	Ground
14	RXCLKIN-	Input	LVDS odd clk -
15	RXCLKIN+	Input	LVDS odd clk +
16	GND	Power	Ground
17	RXIN02-	Input	LVDS odd data 2-
18	RXIN02+	Input	LVDS odd data 2+
19	GND	Power	Ground
20	RXIN03-	Input	LVDS odd data 3-
21	RXIN03+	Input	LVDS odd data 3+
22	GND	Power	Ground
23	NC	-	Keep floating
24	NC	-	Keep floating
25	GND	Power	Ground

26	NC	-	Keep floating
27	NC	-	Keep floating
28	SELB(DINT)	Input	Input Input data format selection DINT = 1 : 8-bit DINT = 0 : 6-bit
29	NC	-	Keep floating
30	GND	Power	Ground
31	LED-	Power	Negative Backlight voltage
32	LED-	Power	Negative Backlight voltage
33	L/R	Input	Horizontal shift direction (source output) selection. RL = 1: Left -> Right(default: Customer to Pull high, internal IC Pull high*) RL = 0: Right -> Left
34	U/D	Input	Vertical shift direction (gate output) selection. TB = 0: Bottom->Top TB = 1: Top ->Bottom (default: Customer to Pull high, internal IC Pull high*)
35	NC	-	Keep floating
36	NC	-	Keep floating
37	NC	-	Keep floating
38	NC	-	Keep floating
39	LED+	Power	Positive Backlight voltage
40	LED+	Power	Positive Backlight voltage

Note: Definition of scanning direction.
Refer to the figure as below:

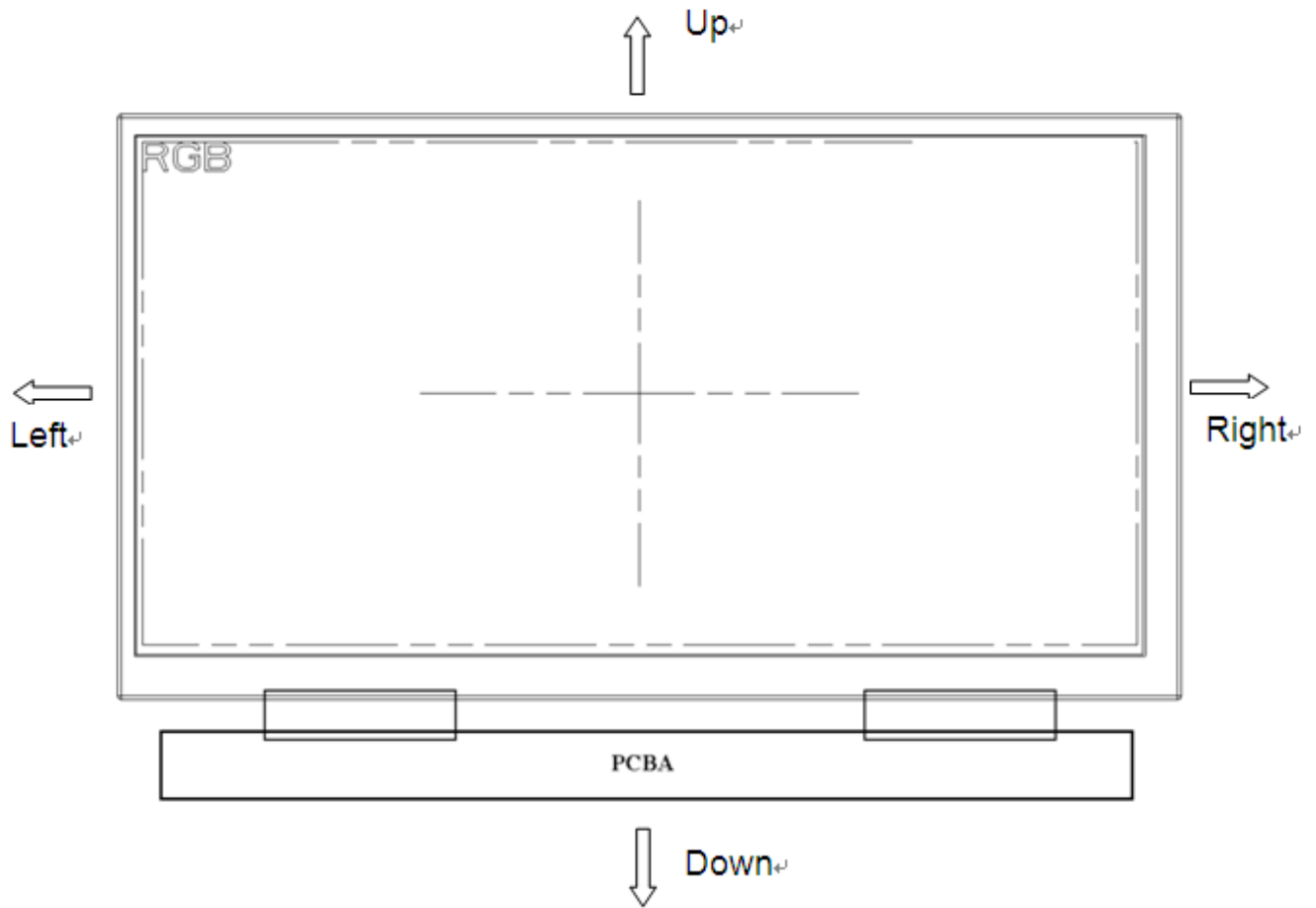

3. Operation Specifications

3.1. Absolute Maximum Ratings

(GND=0V, Note 1)

Item	Symbol	Values		Unit	Remark
		Min.	Max.		
Power voltage	V_{DD}	-0.3	3.96	V	
Operation Temperature	T_{OP}	-30	85	°C	
Storage Temperature	T_{ST}	-40	90	°C	
LED Reverse Voltage	VR	(TBD)	(TBD)	V	Each LED
LED Forward Current	IF		(TBD)	mA	Each LED

Note 1: The absolute maximum rating values of this product are not allowed to be exceeded at any times. Should a module be used with any of the absolute maximum ratings exceeded, the characteristics of the module may not be recovered, or in an extreme case, the module may be permanently destroyed.

3.1.1. Typical Operation Conditions

(GND= $A_{V_{SS}}$ =0V, Note 1)

Item	Symbol	Values			Unit	Remark
		Min.	Typ.	Max.		
Power voltage	V_{DD}	3.0	3.3	3.6	V	Note 1
Input logic high voltage	V_{IH}	$0.7 V_{DD}$	-	V_{DD}	V	Note 2
Input logic low voltage	V_{IL}	GND	-	$0.3 V_{DD}$	V	

Note 1: V_{DD} setting should match the signals output voltage of customer's system board .

Note 2: RESET,STBYB, BISTEN,RL,TB,S_SCS,S_SCLK,S_SDA,MODE,FCS,DINT

3.1.2. Current Consumption

(GND=AV_{SS}=0V)

Item	Symbol	Values			Unit	Remark
		Min.	Typ.	Max.		
Current for Driver	I _{DD}		(TBD)		mA	V _{DD} = 3.3V

3.1.3. Backlight Driving Conditions

Item	Symbol	Values			Unit	Remark
		Min.	Typ.	Max.		
Voltage for LED backlight	V _L	16.2	18.6	20.4	V	Note 1
Current for LED backlight	I _L		260		mA	
LED life time	-	20000			Hr	Note 2

Note 1: The LED Supply Voltage is defined by the number of LED at Ta=25°C and I_L = 320mA

Note 2: The “LED life time” is defined as the module brightness decrease to 50% original brightness at Ta=25°C and I_L =TBDmA. The LED lifetime could be decreased if operating I_L is larger than TBDmA.

3.2. Power Sequence

$VDD(VDD1/2) = 3.0 \sim 3.6V$

a. Power on:

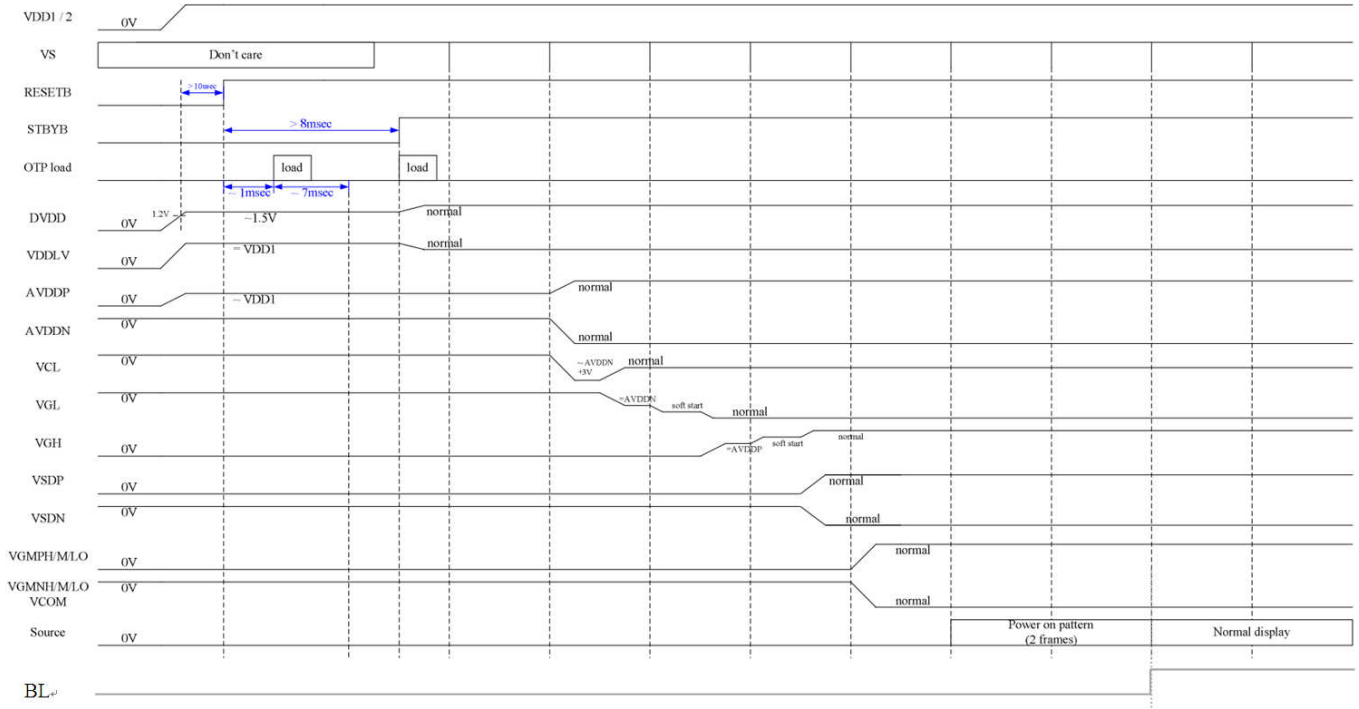

b. Power off:

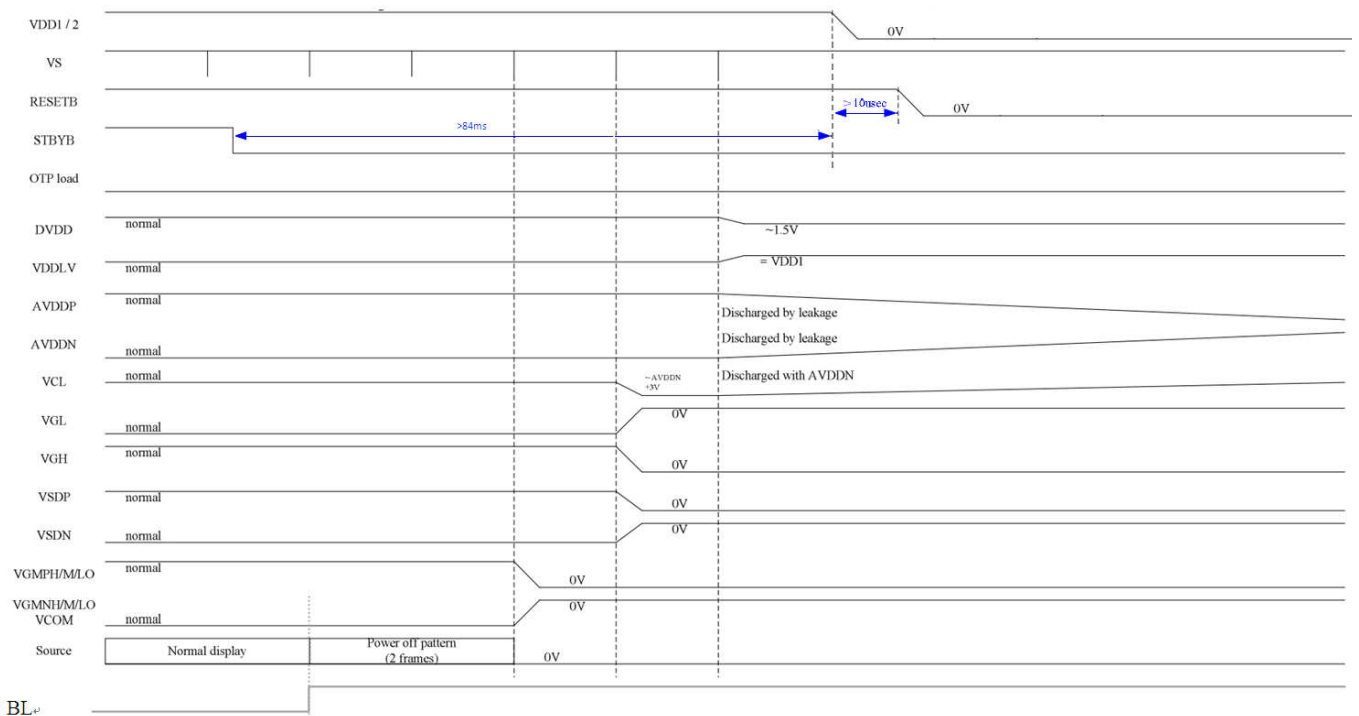

Note: The sequences of OTP load, DVDD, VDDL, AVDDP, AVDDN, VCL, VGL, VGH, VSDP, VSDN, VGMPH/M/LO and VGMNH/M/LO are only for reference.

3.3. Timing Characteristics

3.3.1. AC Electrical Characteristics

Parameter	Symbol	Spec.			Unit	Remark
		Min.	Typ.	Max.		
Clock frequency	FLVCYC	10	-	85	MHz	Frame rate=60Hz
Clock Period	TLVCYC	11.76	-	100	Nsec	Frame rate=60Hz
1 data bit time	UI	-	1/7	-	TLVCYC	
Position 1	TPOS1	-0.2	0	0.2	UI	
Position 0	TPOS0	0.8	1	1.2	UI	
Position 6	TPOS6	1.8	2	2.2	UI	
Position 5	TPOS5	2.8	3	3.2	UI	
Position 4	TPOS4	3.8	4	4.2	UI	
Position 3	TPOS3	4.8	5	5.2	UI	
Position 2	TPOS2	5.8	6	6.2	UI	
Input eye width	TEYEW	0.6	-	-	UI	
Input eye border	TEX	-	-	0.2	UI	
LVDS wake up time	TENLVDS	-	-	150	ns	

3.3.2. Input Clock and Data Timing Diagram

LVDS input timing

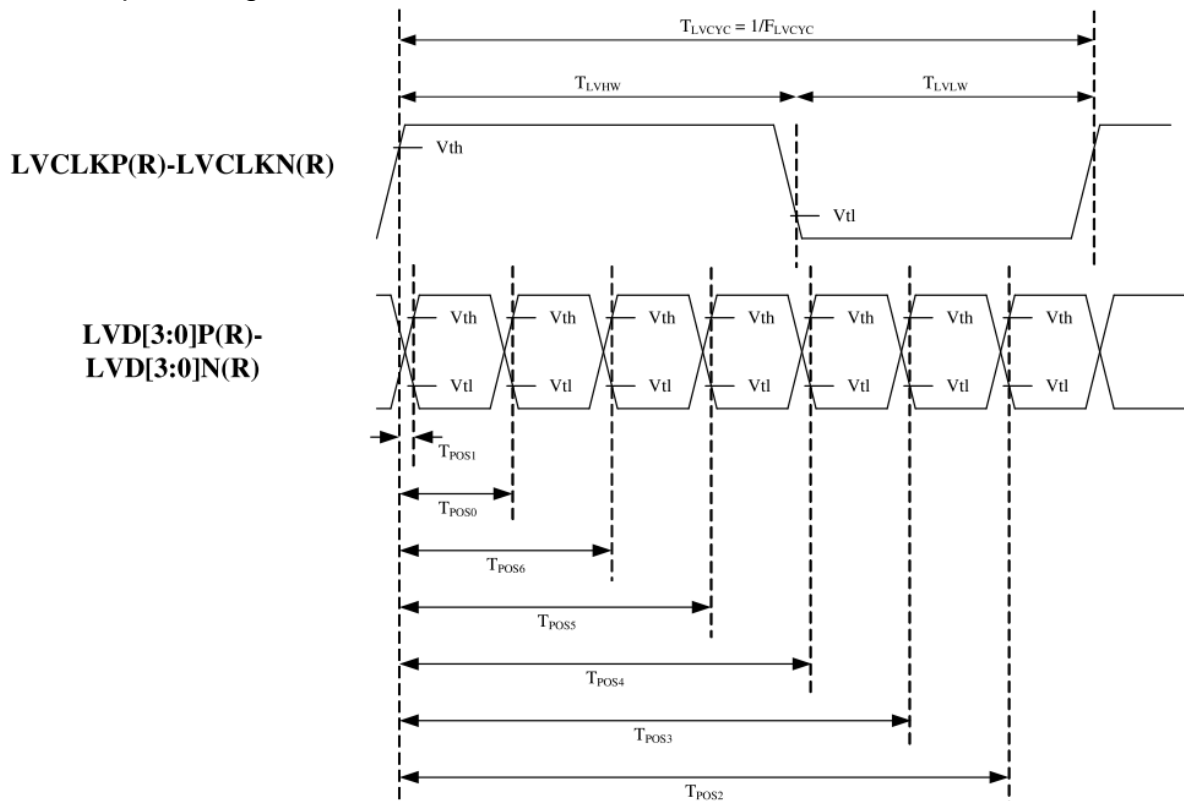

Single-ended:

LVD[3:0]P,

LVD[3:0]N

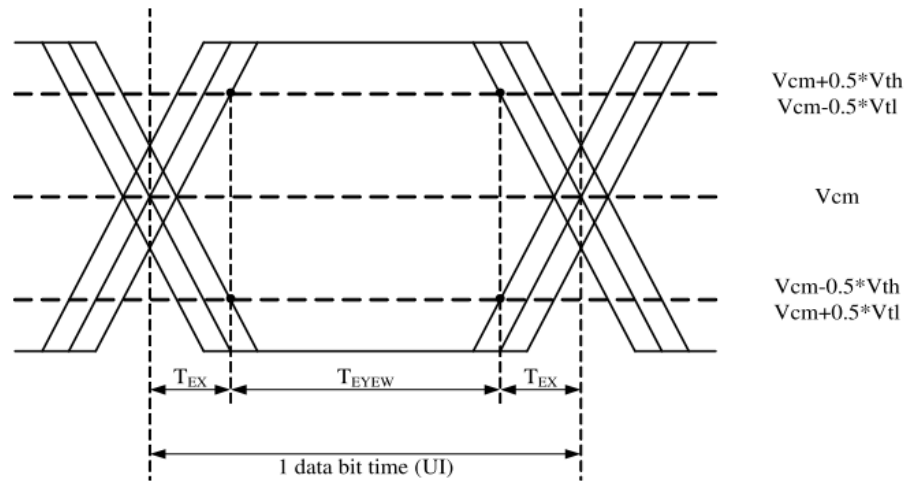

LVDS input eye diagram

Differential:

LVD[3:0]P-LVD[3:0]N

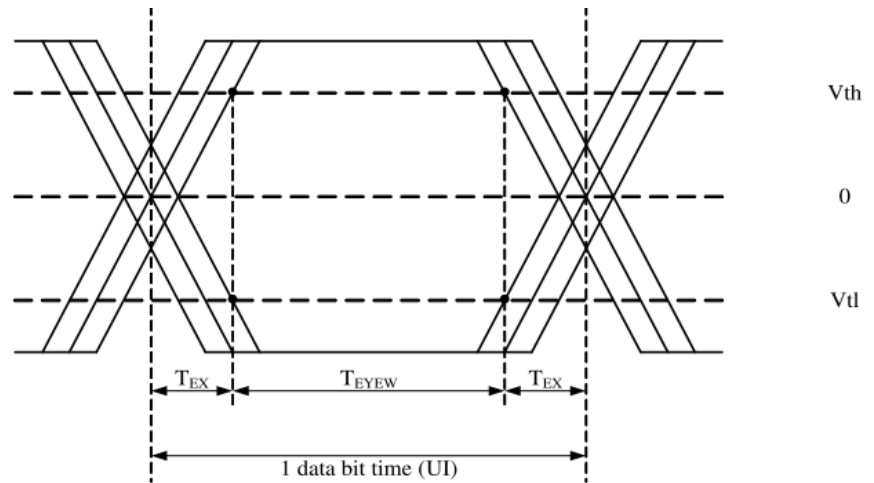

LVDS input eye diagram

3.3.3. DC Electrical Characteristics

Parameter	Symbol	Spec.			Unit	Condition
		Min.	Typ.	Max.		
Differential input high Threshold voltage	Vth	-	-	+0.1	V	Vcm=1.2V
Differential input low threshold voltage	Vtl	-0.1	-	-	V	
Differential input common Mode voltage	Vcm	1	1.2	1.8- Vid /2	V	-
LVDS input voltage	V _{INLV}	0.7		1.8	V	
Differential input voltage	Vid	0.2	-	0.6	V	-
Differential input leakage Current	I _{lvleak}	-10	-	+10	μA	-
Termination Resistor	Zid	80	100	120	Ω	-

Single-ended:
LVCLKP(R),
LVCLKN(R),
LVD[3:0]P(R),
LVD[3:0]N(R)

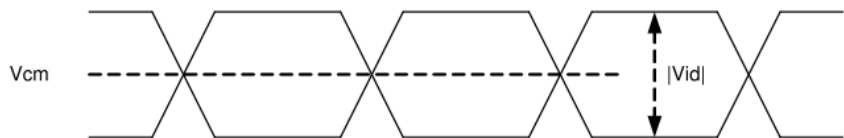

Differential:
LVCLKP(R)-LVCLKN(R),
LVD[3:0]P(R)-
LVD[3:0]N(R)

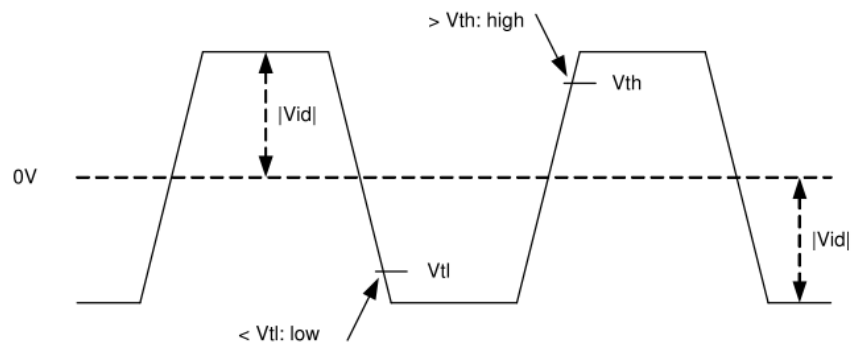

3.3.4. Timing

Parameter	Symbol	Values			Unit	Remark
		Min.	Typ.	Max.		
DCLK Frequency	F DCLK	58.5	63.7	76.3	MHz	Frame rate=60Hz
Horizontal valid data	t hd	1280			DCLK	
Hsync Pulse Width	t hpw	1	2	172	DCLK	
Hsync back porch	t hbp	5	16	173	DCLK	
Hsync front porch	t hfp	19	44	187	DCLK	
1 Horizontal Line	t h	1336	1340	1472	DCLK	
Vertical valid data	t vd	720			H	
Vsync Pulse Width	t vpw	1	2	138	H	
Vsync back porch	t vbp	5	5	139	H	
Vsync front porch	t vfp	5	67	139	H	
1 Vertical field	t v	730	792	664	H	

Note: $t_{hbp}+t_{hpw}+t_{hfp} \geq 56 \text{ DCLK}$, $t_{vbp}+t_{vpw}+t_{vfp} \geq 10$.

3.3.5. Data Input Format

LVDS, 6-bit

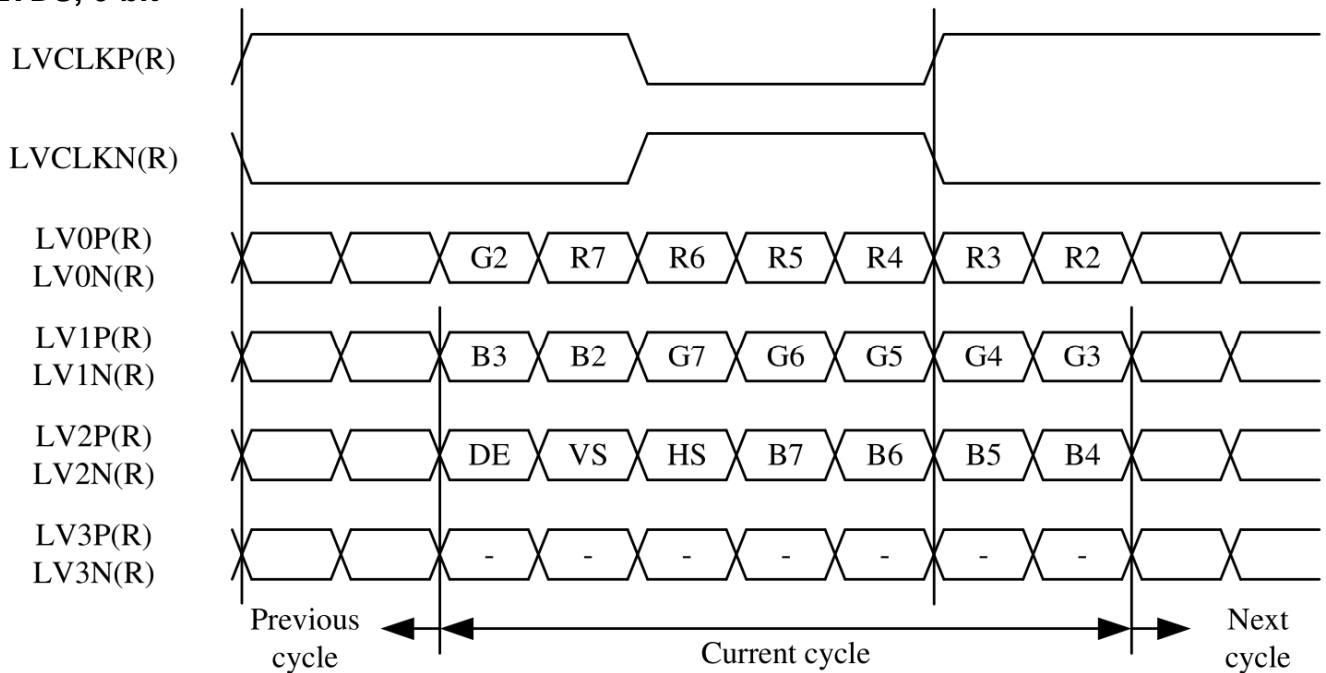

LVDS, 8-bit, VESA format

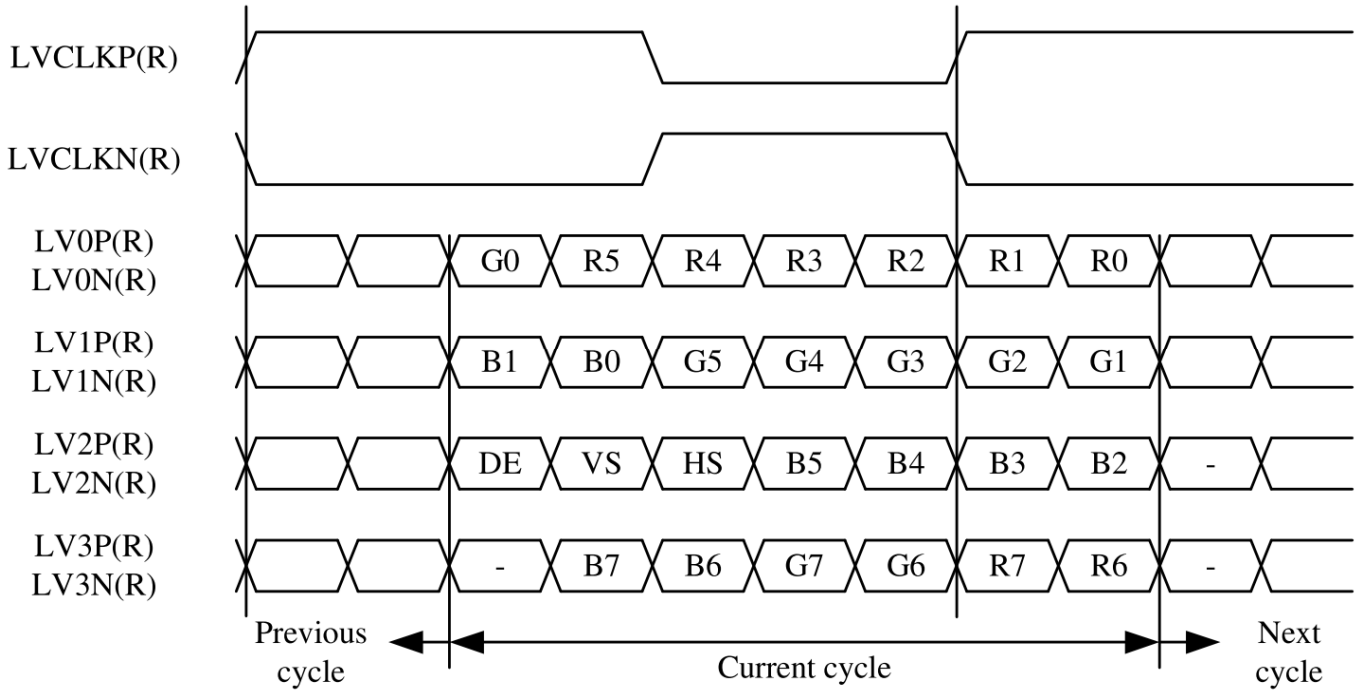

LVDS, 8-bit, JEIDA format

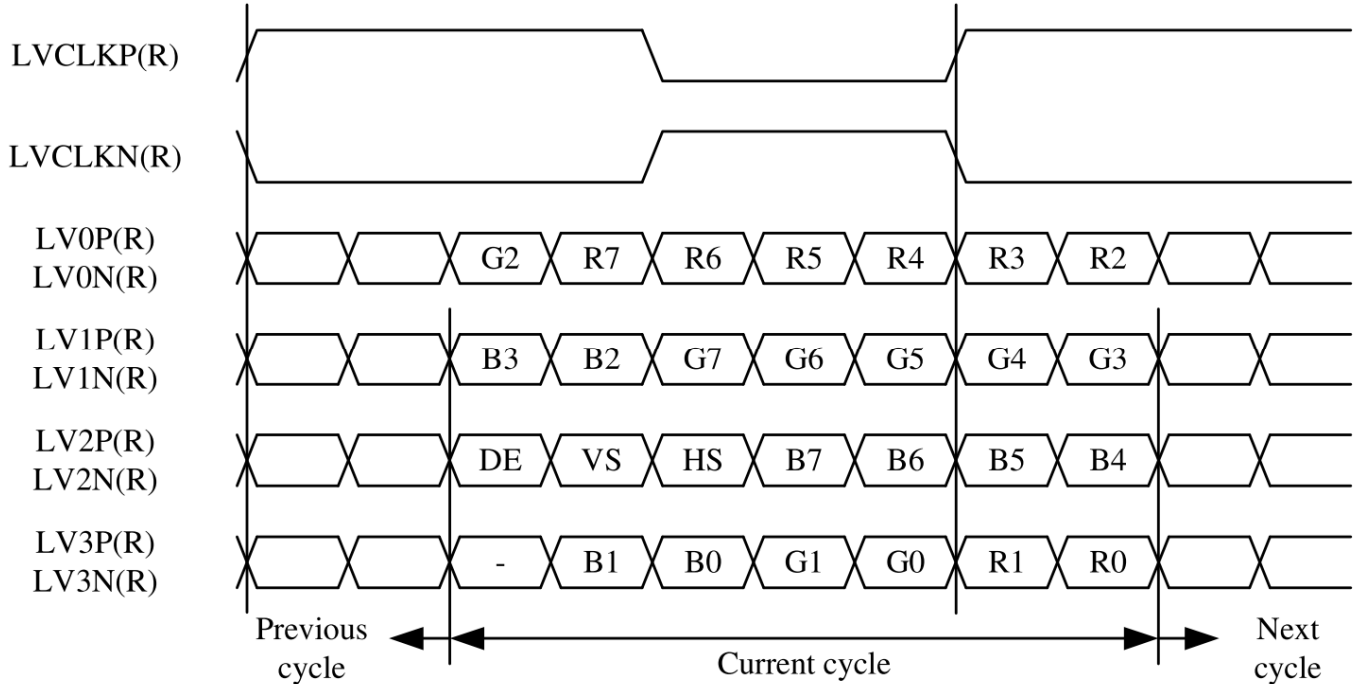

3.3.6 Reset timing

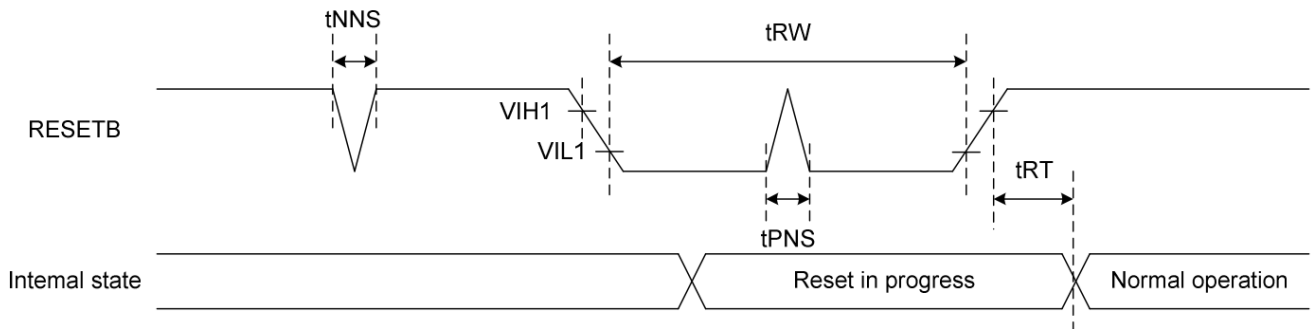

(VDD=3.3V~3.6V)

Signal	Paramete	Symbol	Spec.			Unit	Remarks
			Min.	Typ.	Max.		
RESETB	Reset pulse width	tRW	10	-	-	us	-
	Reset complete time	tRT	-	-	5	us	-
	Positive spike noise width	tPNS	-	-	100	ns	-
	Negative spike noise width	tNNS	-	-	100	ns	-

4. Optical Specifications

Item	Symbol	Condition	Values			Unit	Remark
			Min.	Typ.	Max.		
Viewing angle (CR≥ 10)	θ_L	$\Phi=180^\circ$ (9 o'clock)		85	-	degree	Note 1
	θ_R	$\Phi=0^\circ$ (3 o'clock)		85	-		
	θ_T	$\Phi=90^\circ$ (12 o'clock)		85	-		
	θ_B	$\Phi=270^\circ$ (6 o'clock)		85	-		
Response time	T_{ON}	Normal $\theta=\Phi=0^\circ$	-	10	20	msec	Note 3
	T_{OFF}		-	15	30	msec	Note 3
Contrast ratio	CR		(TBD)	1000	-	-	Note 4
Color chromaticity	W_X		0.26	0.31	0.36	-	Note 2 Note 5 Note 6
	W_Y		0.28	0.33	0.38	-	
Luminance	L		600	750	-	cd/m ²	Note 6
Luminance uniformity	Y_U		75	80	-	%	Note 7

Test Conditions:

1. $DV_{DD}=3.3V$, $I_L=TBDmA$ (Backlight current), the ambient temperature is 25°C.
2. The test systems refer to Note 2.

Note 1: Definition of viewing angle range

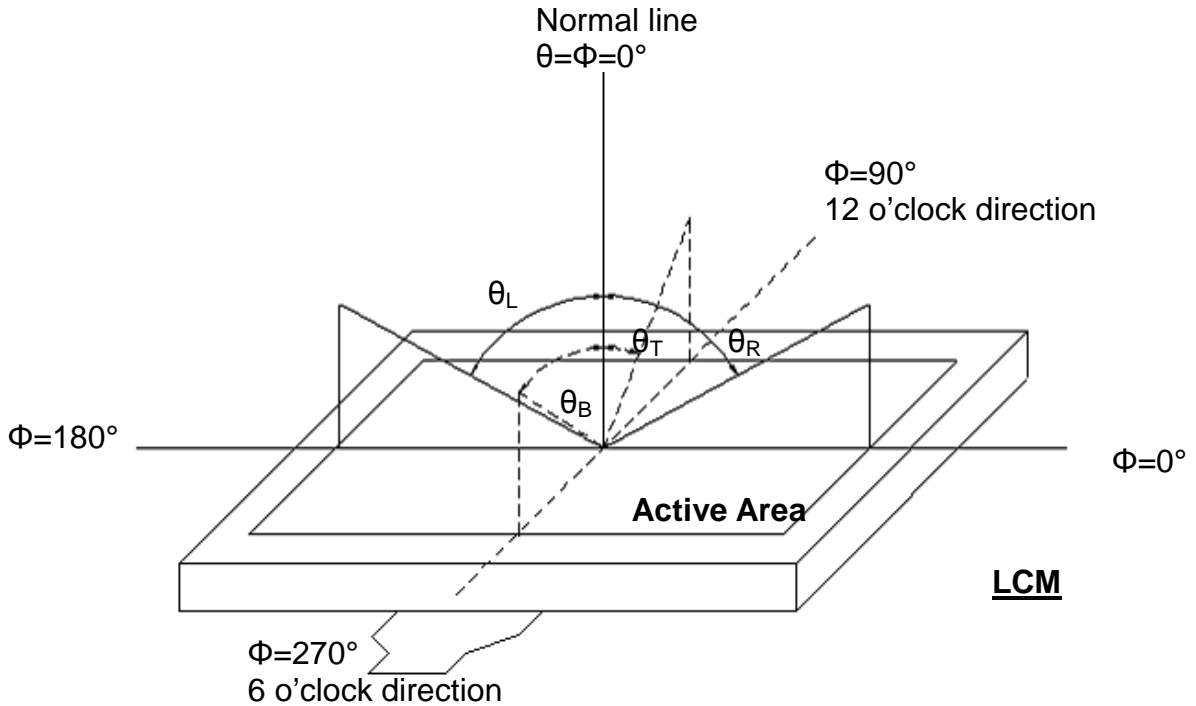

Fig. 4-1 Definition of viewing angle

Note 2: Definition of optical measurement system.

The optical characteristics should be measured in dark room. After 30 minutes operation, the optical properties are measured at the center point of the LCD screen. (Response time is measured by Photo detector TOPCON BM-7, other items are measured by BM-5A/Field of view: 1°/Height: 500mm.)

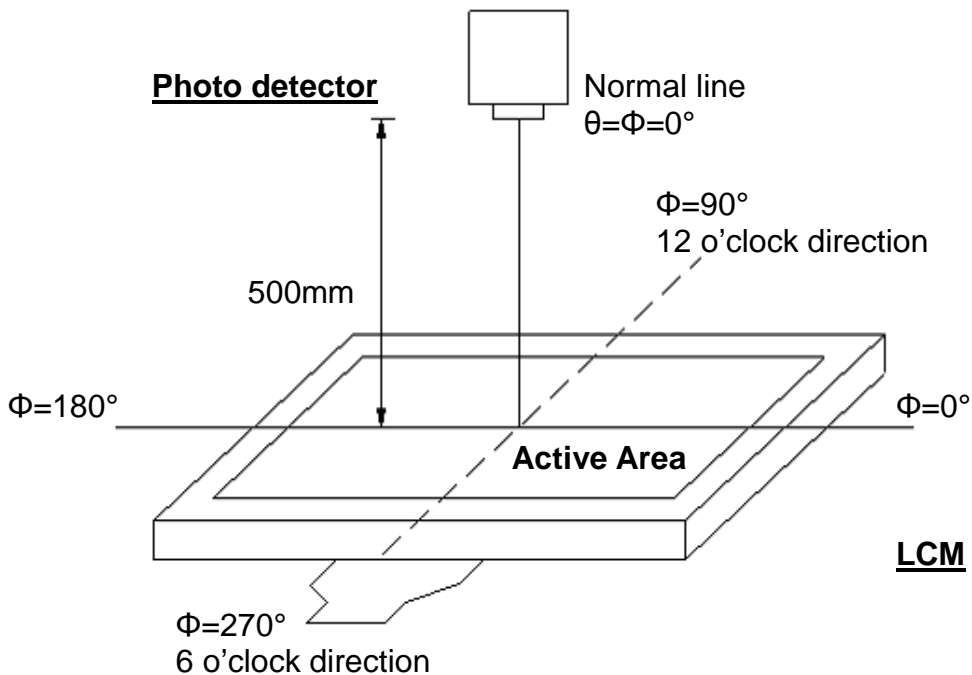

Fig. 4-2 Optical measurement system setup

Note 3: Definition of Response time

The response time is defined as the LCD optical switching time interval between "White" state and "Black" state. Rise time (T_{ON}) is the time between photo detector output intensity changed from 90% to 10%. And fall time (T_{OFF}) is the time between photo detector output intensity changed from 10% to 90%.

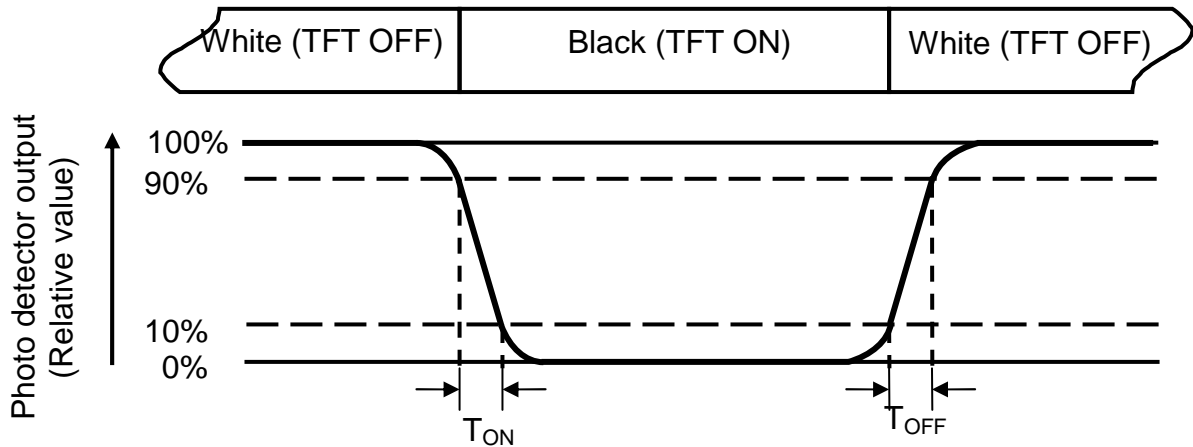

Fig. 4-3 Definition of response time

Note 4: Definition of contrast ratio

$$\text{Contrast ratio (CR)} = \frac{\text{Luminance measured when LCD on the "White" state}}{\text{Luminance measured when LCD on the "Black" state}}$$

Note 5: Definition of color chromaticity (CIE1931)

Color coordinates measured at center point of LCD.

Note 6: All input terminals LCD panel must be ground while measuring the center area of the panel. The LED driving condition is $I_L=(180\text{mA})$

Note 7: Definition of Luminance Uniformity

Active area is divided into 9 measuring areas (Refer to Fig. 4-4).Every measuring point is placed at the center of each measuring area.

$$\text{Luminance Uniformity (Yu)} = \frac{B_{min}}{B_{max}}$$

L-----Active area length W----- Active area width

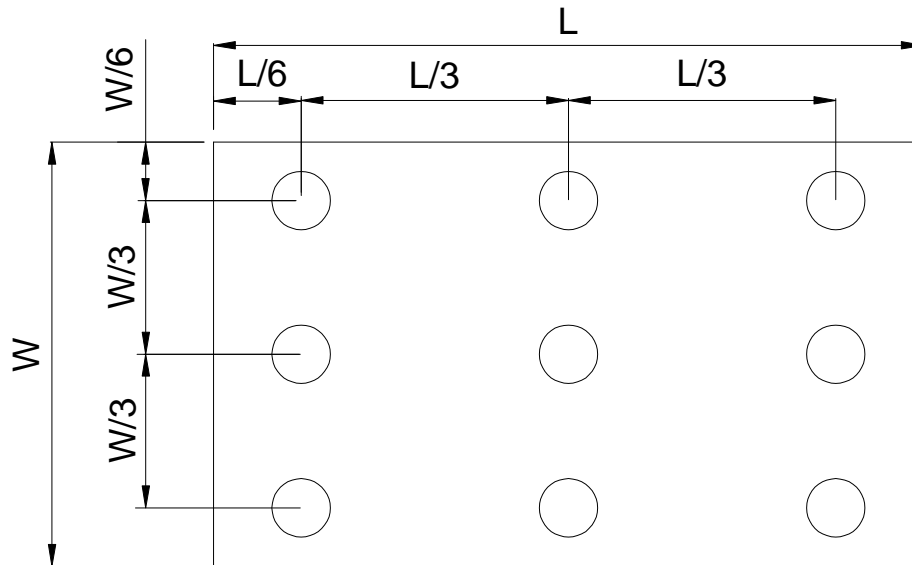

Fig. 4-4 Definition of measuring points

B_{max}: The measured maximum luminance of all measurement position.

B_{min}: The measured minimum luminance of all measurement position.

5. Reliability Test Items

Item	Test Conditions	Remark
High Temperature Storage Test	90°C, 240 hours	Note 1 Note 2 Note 4
Low Temperature Storage Test	-40°C, 240 hours	
High Temperature Operation Test	85°C, 240 hours	
Low Temperature Operation Test	-30°C, 240 hours	
High Temperature & High Humidity Operation Test	60°C, RH 90%, 240hours	
Thermal Shock	[(-30°C 30min)→(85°C 30min)]/cycle · (Ramp rate ≥ 20°C/min) , 100cycles	
ESD Test (Non-Operation)	Condition 1 : C = 150pF, R = 330Ω Contact Discharge, ± 8KV Condition 2 : C = 150pF, R = 330Ω, Air Discharge, ± 15KV	Note 1
Mechanical Shock	100G, 6ms, half sine wave, 3 times for each direction of ±X, ±Y, ±Z	Note 1 Note 3
Mechanical Vibration	Frequency: 10 ~55~10Hz;Sweep Mode: Log Sweep Sweep time: 1Oct/min; Acceleration: 1.5G;Test time:2 hr for each direction of X, Y, Z.	Note 1 Note 3
Packaging Vibration Test	1.47Grms X, Y, Z three axes (30min /axis) [頻譜 : 5Hz(0.015G ² /Hz) , 100Hz(0.015G ² /Hz) , 200Hz(0.0037G ² /Hz)]	
Packaging Drop Test	1corner, 3edges, 6faces (1 time/direction) <follow ISTA(1A) 高度> 0kg ≤ W <10kg : 76cm, 10kg ≤ W <19kg : 61cm, 19kg ≤ W <28kg : 46cm, 28kg ≤ W <45kg : 31cm, 45kg ≤ W ≤ 68kg : 20cm	

Note 1: Criteria: Normal display image with no obvious non-uniformity and no line defect.

Note 2: Evaluation should be tested after storage at room temperature for more than two hour

Note 3: At testing Vibration and Shock, the fixture in holding the module has to be hard and rigid enough so that the module would not be twisted or bent by the fixture.

Note 4: A certain level of Mura (non-uniformity) of dark / black image will happen several days after high temperature testing (H.T.T.). There is a slowly part recovery over a long time (several months). Such a long exposure time like in H.T.T. will normally not happen in a real application. Therefore the test H.T.T. was introduced to simulate cycles with normal conditions in-between but with the same total exposure time what show a significant reduced Mura.

The root cause is related to tension generated due to different amount of shrinking in the stack of layers in the polarizer sheet. The effect is more significant on larger displays like this size. An investigation into alternative polarizer material showed that there is no better alternative currently available.

6. General Precautions

6.1. Safety

Liquid crystal is poisonous. Do not put it in your mouth. If liquid crystal touches your skin or cloths, wash it off immediately by using soap and water.

6.2. Handling

1. The LCD panel is plate glass. Do not subject the panel to mechanical shock or to excessive force on its surface.
2. The polarizer attached to the display is easily damaged. Please handle it carefully to avoid scratch or other damages.
3. To avoid contamination on the display surface, do not touch the module surface with bare hands.
4. Keep a space so that the LCD panels do not touch other components.
5. Put cover board such as acrylic board on the surface of LCD panel to protect panel from damages.
6. Transparent electrodes may be disconnected if you use the LCD panel under environmental conditions where the condensation of dew occurs.
7. Do not leave module in direct sunlight to avoid malfunction of the ICs.

6.3. Static Electricity

1. Be sure to ground module before turning on power or operating module.
2. Do not apply voltage which exceeds the absolute maximum rating value.

6.4. Storage

1. Store the module in a dark room where must keep at $25\pm 10^{\circ}\text{C}$ and 65%RH or less.
2. Do not store the module in surroundings containing organic solvent or corrosive gas.
3. Store the module in an anti-electrostatic container or bag.

6.5. Cleaning

1. Do not wipe the polarizer with dry cloth. It might cause scratch.
2. Only use a soft sloth with IPA to wipe the polarizer, other chemicals might permanent damage to the polarizer.

7. Mechanical Drawing

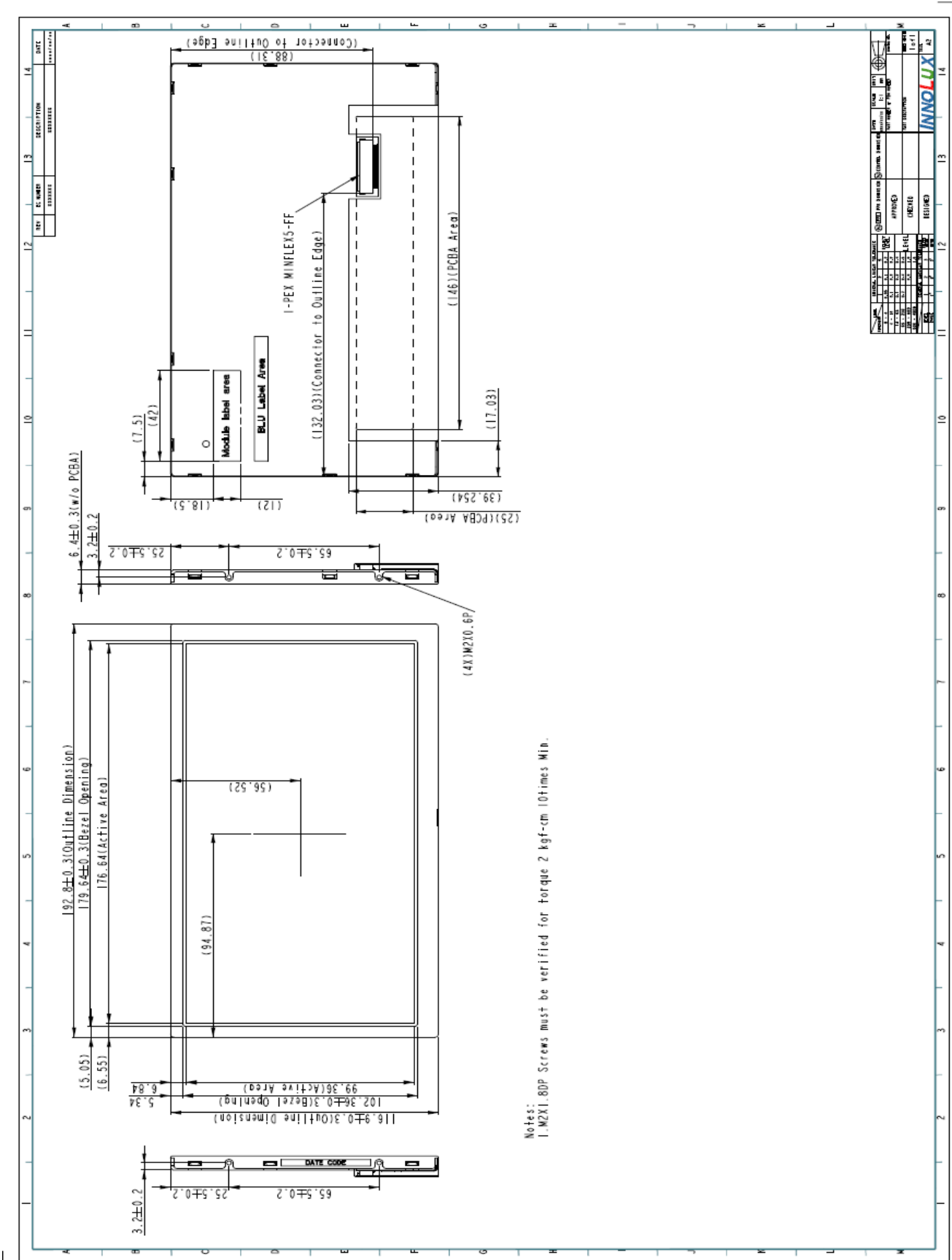

Notes:
1. M2X1.00P Screws must be verified for torque 2 kgf-cm 10Times Min.

8. Package Drawing

8.1 Packaging Material Table

No.	Item	Model (Material)	Dimensions(mm)	Unit Weight (kg)	Quantity	Remark
1	LCM Module	Model name	192.8×116.9×6.4	0.205	TBD	
2	EPP Box	EPP	(TBD)	(TBD)	1	
3	A/S Bag	PE	(TBD)	(TBD)	1	
4	Carton	Corrugated paper	(TBD)	(TBD)	1	
5	Total weight	(TBD)				

8.2 Packaging Quantity

TBD

8.3. Packaging Drawing

TBD

8.4. Shipping Drawing

TBD